

Compact Compressor

Supplies compressed air in an environment with no air source such as cobots, AGV and AMRs



Compact

Width 154 mm x **Height** 134 mm x **Depth** 100 mm

Lightweight

Weight 3.5 kg (Compressor: 3.1 kg, Controller: 0.4 kg)



Installed as an air or vacuum source for grippers of cobot

Grippers for collaborative robots
 · Air grippers
 · Vacuum pads, etc.

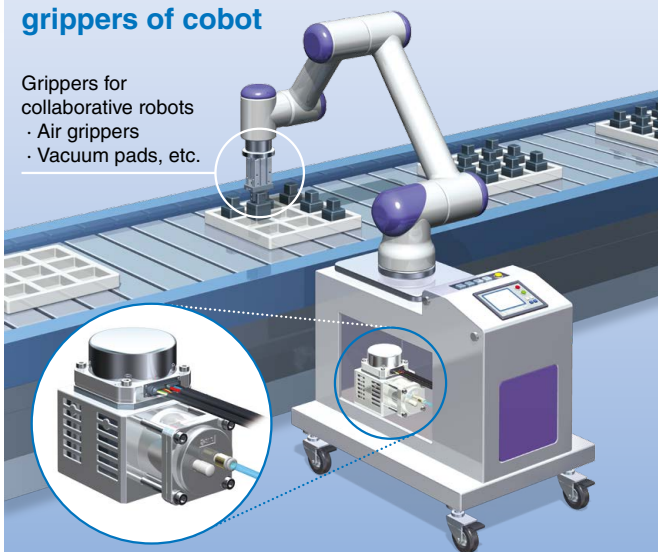

A single unit can be used to provide positive or vacuum pressure (vacuum pump).

Max. discharge pressure: 0.55 MPa
 Ultimate vacuum pressure: -70 kPa

* Use of the product as a vacuum pressure source after it is used as a positive pressure source (and vice versa) is prohibited because doing so degrades the performance.

Oil-free

Noise: 55 dB or less
 (When the silencer ANB1-01 is installed)
 (When supplying positive pressure)

CRP Series



CAT.ES30-24A

Compact Compressor *CRP Series*

Max. flow rate of 10 L/min (ANR)

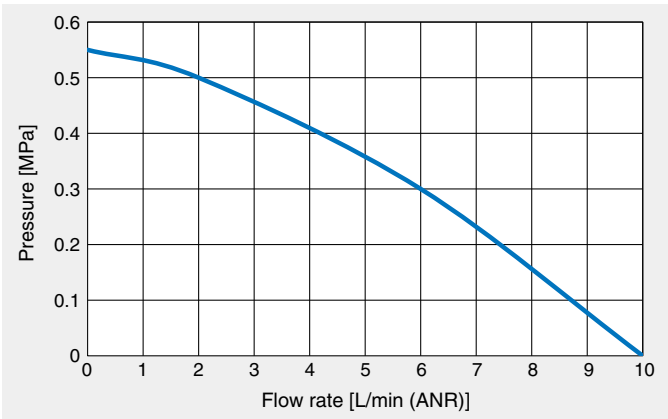

Reaches the ultimate vacuum pressure (-70 kPa) in 0.2 seconds

The time to reach the ultimate vacuum pressure when the vacuum pad is placed about 3 meters from the compressor

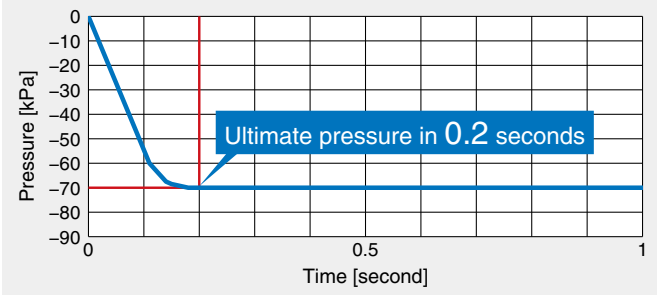

Applications

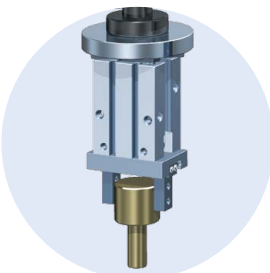

Air gripper

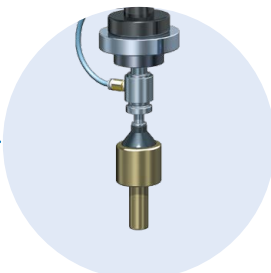

Vacuum pad

Robots

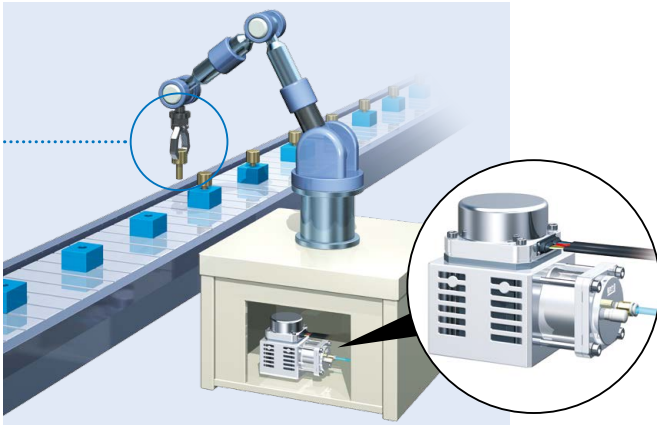

Autonomous Mobile Robot

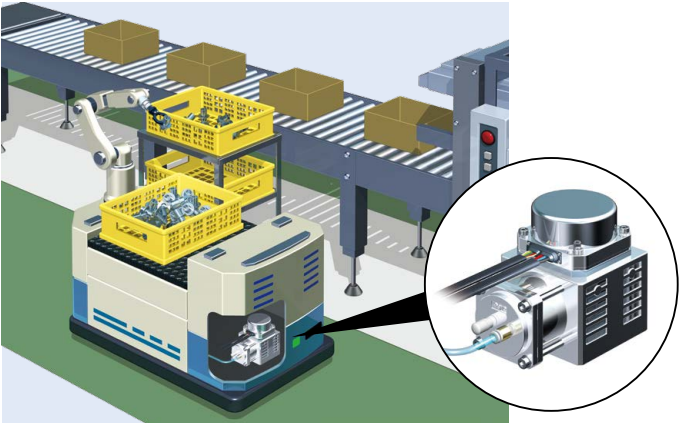

Pressurizing parts

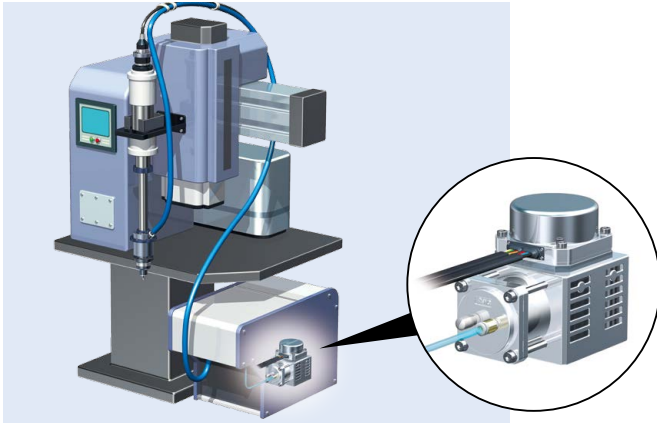

Environments without an air source

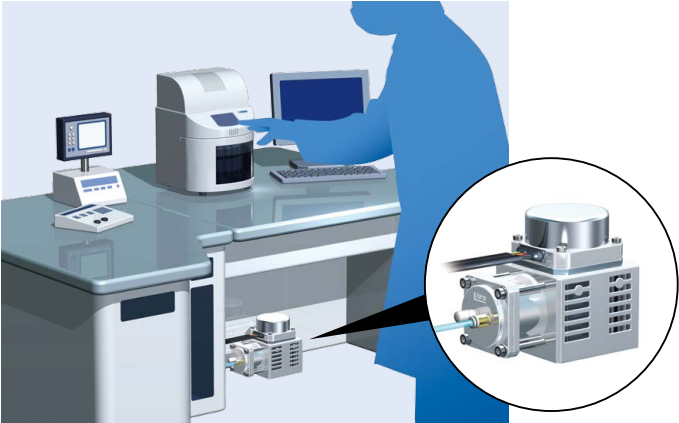

At max. 15 cpm, operation with a gripping force of 0.25 MPa is possible.*1

*1 ISE20A-Y□-01-J-X603 initial settings

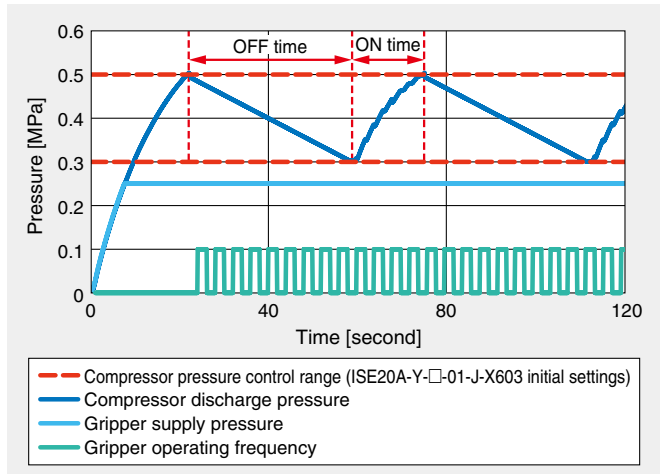

Test circuit

Conditions

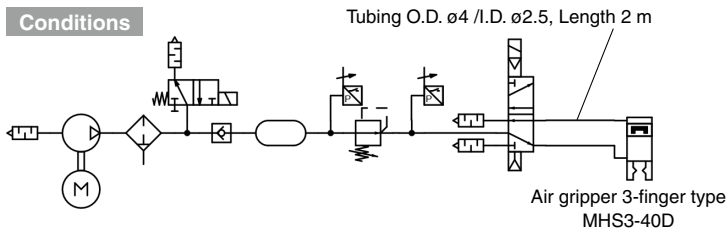

Calculate the air consumption amount and check whether the CRP is applicable based on the required pressure and the air consumption amount. For continuous operation, be sure to install a suitable tank (provided by the customer) for the required air volume.

Alarm

Alarm LED turns on or flashes when an error is detected

* Refer to the operation manual for possible causes and troubleshooting.

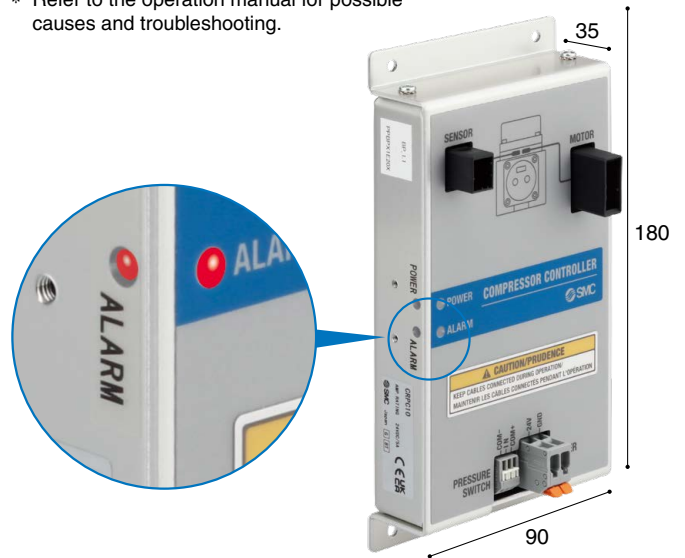

Can be mounted from 2 directions

Horizontal Mounting

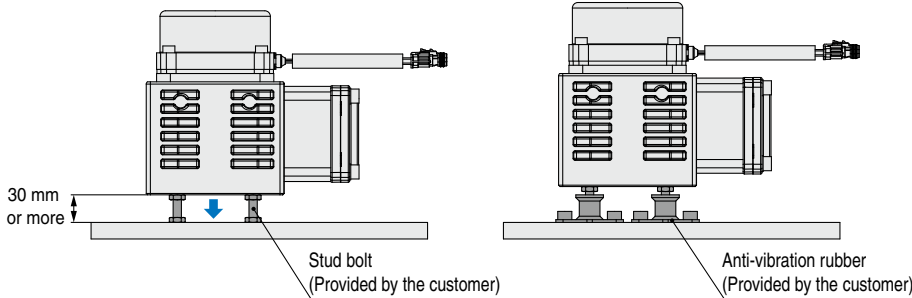

Vertical Mounting

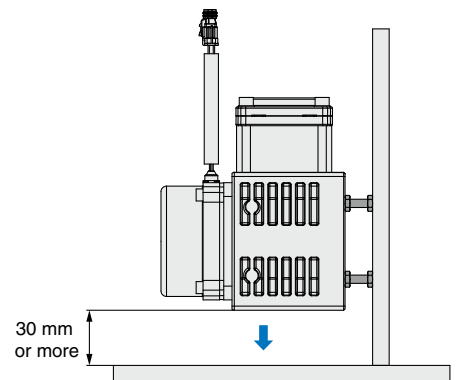

* Use anti-vibration rubber if a large amount of vibrations are transferred to the embedded surface.
 * When installing, provide a space of 30 mm or more as shown for air intake and heat vent. Refer to the Specific Product Precautions (p. 9) and operation manual for details.

CONTENTS

| | | | |
|--------------------------|------|-----------------------------------|------|
| System Construction..... | p. 3 | Flow Rate Characteristics..... | p. 6 |
| How to Order..... | p. 4 | Dimensions..... | p. 7 |
| Specifications..... | p. 5 | Specific Product Precautions..... | p. 9 |

System Construction (Positive pressure applications)

* Refer to the operation manual for more information on wiring.

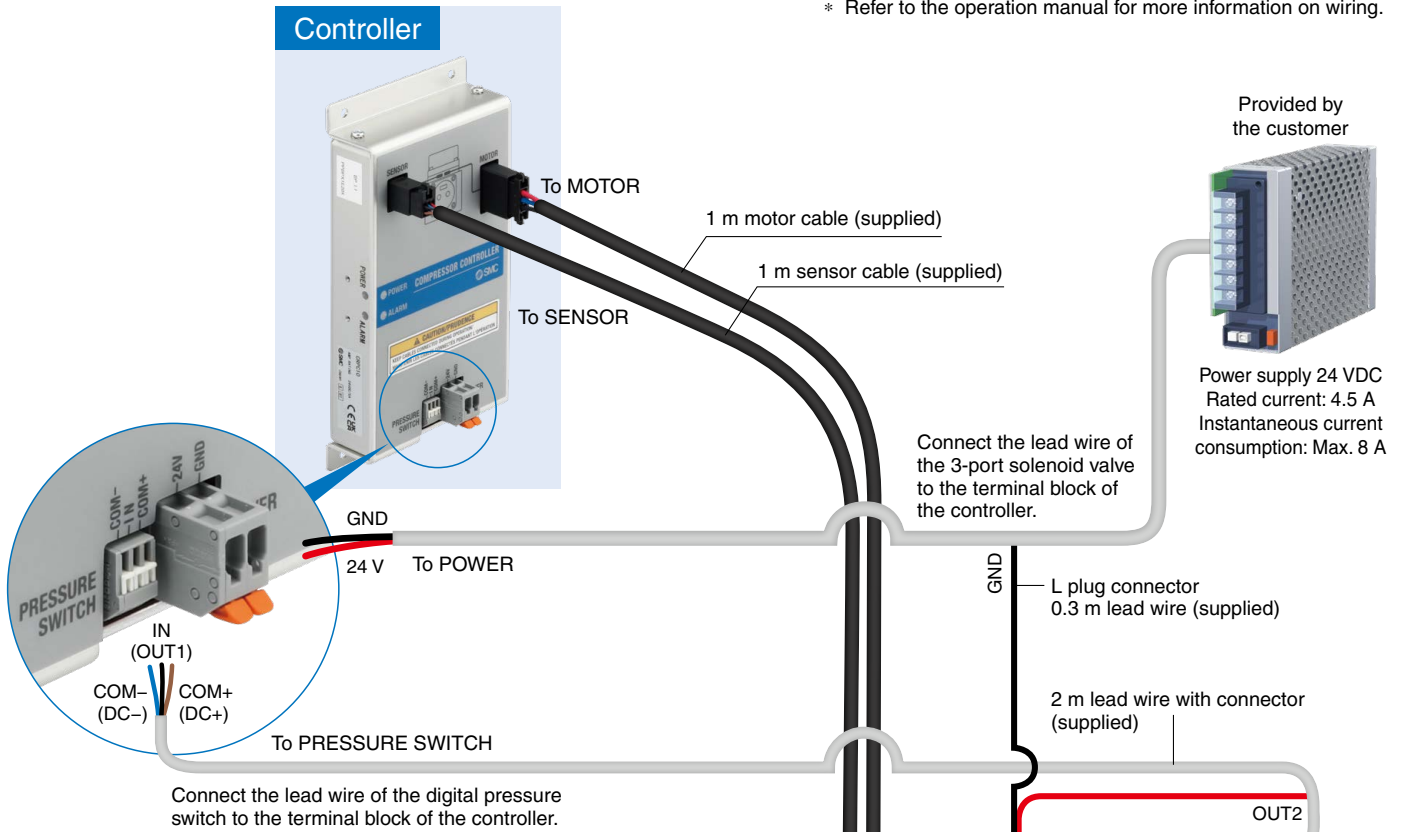

Compact Compressor

Vacuum applications

The system configuration is the same as that of the positive pressure except for the piping positions.

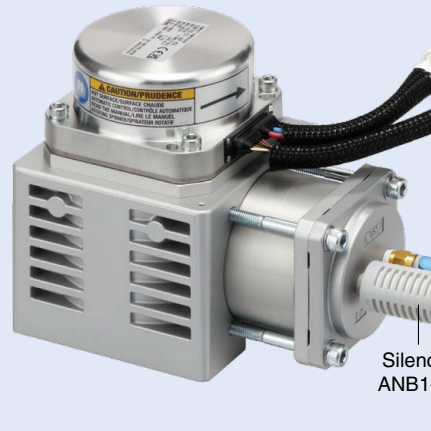
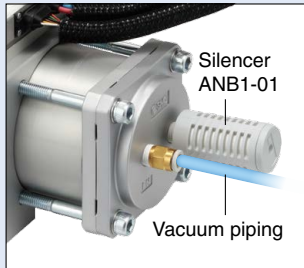

Pneumatic equipment

Pneumatic circuit diagram

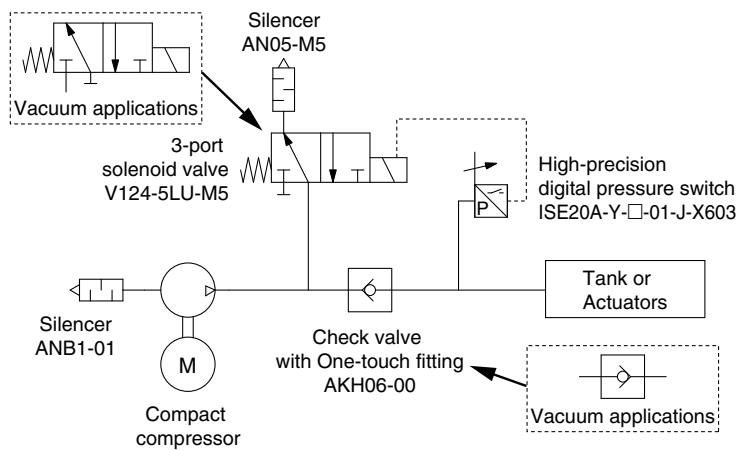

Application example

The compressor can power single driving devices including actuators used for arms and ends of collaborative robots.



More information can be viewed here.

Collaborative robots

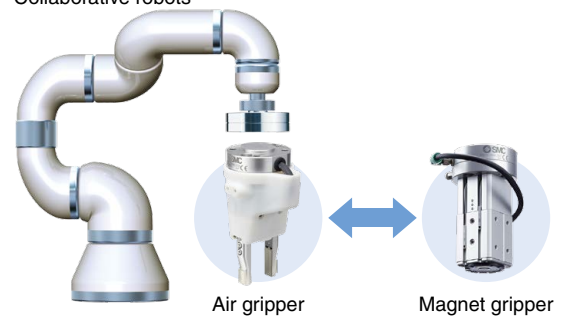

Compact Compressor

CRP Series



How to Order

CRP10 - **S** **1** - **B** **M** - **K** **V**

1
2
3
4
5
6

1 Controller mounting

| Symbol | Mounting |
|----------|---------------------|
| S | Screw mounting |
| D | DIN rail mounting*1 |

*1 The DIN rail mounting bracket is included in the package, but a DIN rail is not supplied.

2 Cable length

| Symbol | Cable length |
|----------|--------------|
| 1 | 1 m |

3 Silencer for inlet port

| Symbol | Part no. | Noise (Positive pressure) |
|------------|----------|---------------------------|
| A | AN10-01 | 62 dB |
| B | ANB1-01 | 55 dB |
| Nil | None | 75 dB |

4 High-precision digital pressure switch

| Symbol | Part no. | Content |
|------------|------------------------|---------------------------------|
| M | ISE20A-Y-M-01-J-X603*1 | Fixed SI unit*2 |
| P | ISE20A-Y-01-J-X603*1 | With units selection function*3 |
| Nil | None | — |

*1 Make sure to connect the PNP output of the high-precision digital pressure switch to the controller. This allows the product to control pressure and operate stop/start (unload/load) functions.

*2 Fixed units: kPa, MPa

*3 Under the New Measurement Act, switches with the units selection function are no longer allowed for use in Japan.

5 Check valve with One-touch fitting for exhausting residual pressure

| Symbol | Part no. | Applicable tubing O.D. |
|------------|----------|------------------------|
| K | AKH06-00 | φ6 |
| Nil | None | — |

6 3-port solenoid valve for exhausting residual pressure

| Symbol | Part no. |
|------------|-------------|
| V | V124-5LU-M5 |
| Nil | None |

* A connector with 300 mm lead wire and exhaust port silencer AN05-M5 are included in the package.

* Refer to the specifications (pp. 5 and 6) for more information of each part and the product.

Specifications

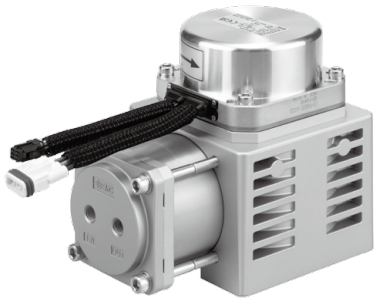

Symbol

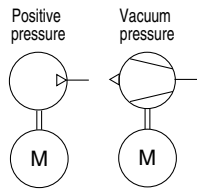

Compressor

| | | |
|---|---------------------------------------|------------|
| Fluid | Air | |
| Compression method | Reciprocating (Oil-free) | |
| Max. discharge pressure / Ultimate vacuum pressure | 0.55 MPa / -70 kPa | |
| Max. discharge flow rate / Max. suction flow rate | 10 L/min (ANR) | |
| Unloader method (ON-OFF) | Pressure switch | |
| Duty cycle*1 | Continuous | |
| Noise*2 | 62 dB or less (With AN10-01 equipped) | |
| | 55 dB or less (With ANB1-01 equipped) | |
| Operating temperature range | 5 to 40°C | |
| Operating humidity range | 80%RH or less (No condensation) | |
| Weight | 3.1 kg | |
| Seal material | Sliding parts | PTFE resin |
| | O-ring | HNBR |

Controller

| | | |
|--|---|-----------------------------------|
| Installation | Separation | |
| Power supply | 24 VDC ±10% | |
| Rated current | 4.5 A (110 W) | |
| Instantaneous current consumption*3 | Max. 8 A (200 W) | |
| LED display | POWER | Green when the power source is ON |
| | ALARM | Red light on or flashing |
| Pressure switch input | IN (Input for pressure switch) | |
| | 1 PNP input | |
| | Input current 3.5 mA ±20% at 24 VDC | |
| Pressure switch options | COM+, COM- (Power supply output for pressure switch) 24 VDC +10%–15%, Max. supply current 200 mA | |
| | High-precision digital pressure switch ISE20 series | |
| | PNP open collector output type ISE20A-Y-□-□-J-X603 | |
| Mounting | Screw mounting / DIN-rail mounting | |
| Cable length | 1 m | |
| Cooling system | Natural air cooling | |
| Operating temperature range | 5 to 40°C | |
| Operating humidity range | 80%RH or less (No condensation) | |
| Insulation resistance | Between batch of external terminals and case 50 MΩ (500 VDC) | |
| Weight | Screw mounting: 340 g / DIN rail mounting: 360 g | |

*1 The time during which the compressor can operate continuously

*2 Values in an anechoic chamber, 1.0 m away from the front of the port (at max. discharge pressure)

Depending on operating and installation conditions, the values may be higher than those shown in the table.

*3 When power supply has overcurrent protection function, use an automatic recovery type or a constant current type.

2 Outputs + Analog Output (Voltage/Current)

3-Screen Display High-Precision Digital Pressure Switch: ISE20A Series



Symbol

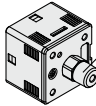
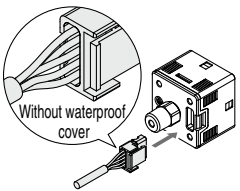

| | | |
|------------------------------|--|--|
| Model | ISE20A-Y-□-01-J-X603 | |
| Rated pressure range | -0.1 to 1 MPa | |
| Output specification | PNP open collector 2 outputs + Copy function | |
| Piping specification | R1/8 |  R1/8 Piping adapter |
| Lead wire | Lead wire with connector (5-core, 2 m lead wire) |  Without waterproof cover |
| Switch output setting | Reversed output | |
| Stopping pressure | 0.5 MPa | |
| Starting pressure | 0.3 MPa | |

* For details, refer to the **Web Catalog**.

* Refer to the operation manual for instructions on how to set the output to vacuum.

Specifications

Symbol

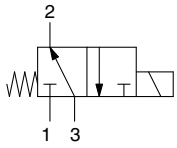

3-Port Solenoid Valve: V100 Series

| Model | V124-5LU-M5 |
|--------------------------------|--|
| Type of actuation | Normally open |
| Rated voltage | 24 VDC |
| Electrical entry | L plug connector (Lead wire: 0.3 m) |
| Light/Surge voltage suppressor | With (Non-polar)/For DC |
| Port size | With sub-plate |
| Silencer | AN05-M5 (Included in the same package) |

* For details, refer to the [Web Catalog](#).

Symbol

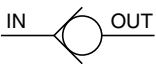

Check Valve with One-touch Fitting: AKH Series

| Model | AKH06-00 |
|-----------------------------|-------------------|
| Type | Straight type |
| Connection | One-touch fitting |
| Applicable tubing O.D. [mm] | ø6 |
| Weight [g] | 5 |

* For details, refer to the [Web Catalog](#).

Symbol



Silencer: AN□ Series

| Model | AN10-01 | ANB1-01 |
|-----------------------------|---------------|----------------------|
| Type | Compact resin | High-noise reduction |
| Thread connection port size | 1/8 | 1/8 |
| Weight [g] | 1 | 10 |

* For details, refer to the [Web Catalog](#).

Flow Rate Characteristics

Positive pressure

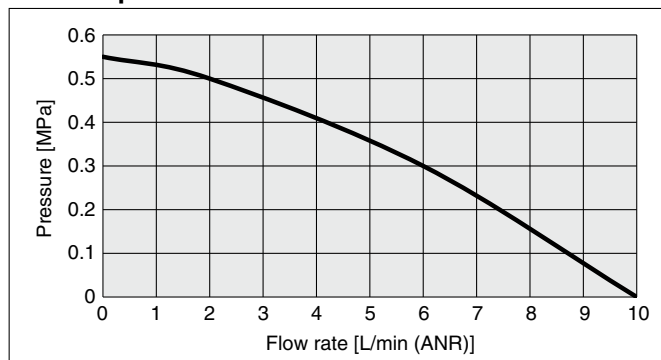

Vacuum

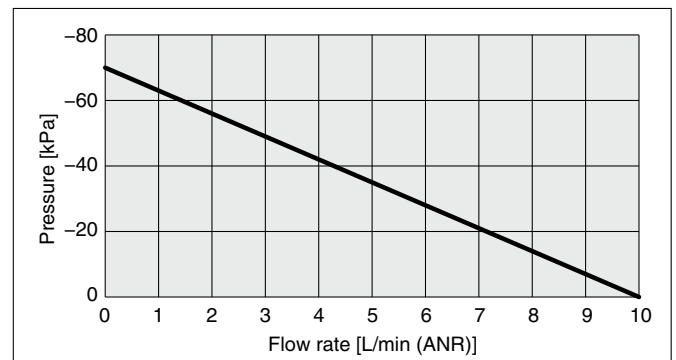

Conditions

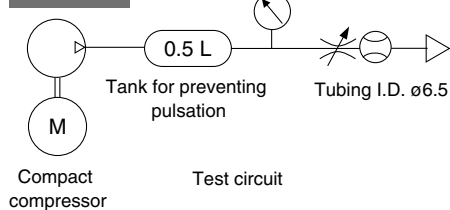

Conditions

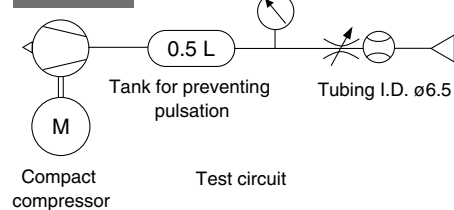

CRP Series

Dimensions

Compressor

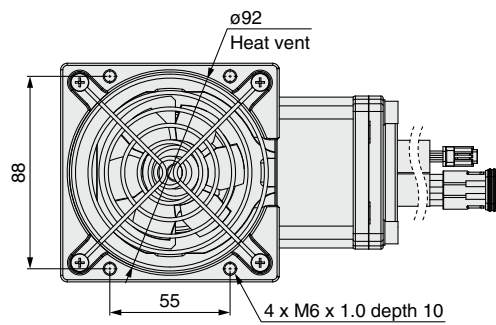
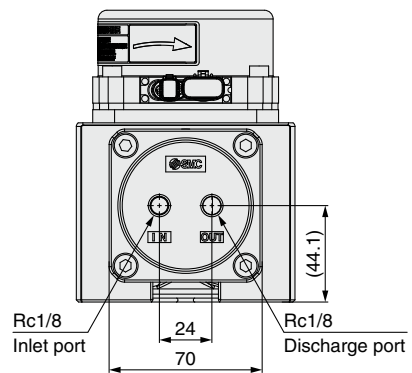
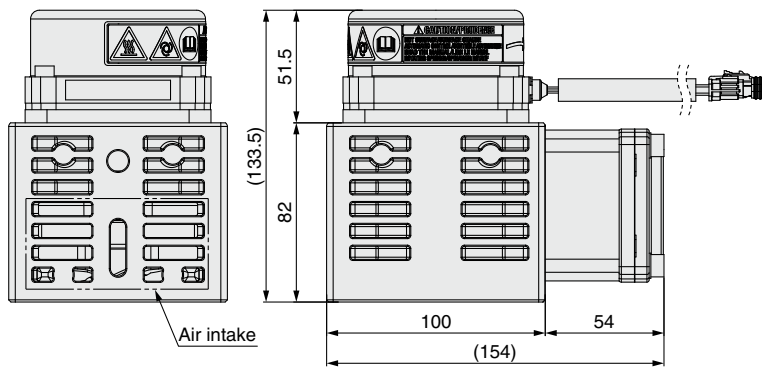
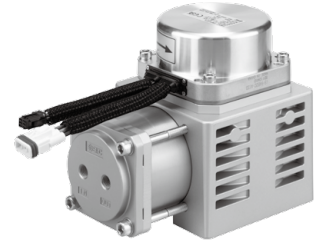
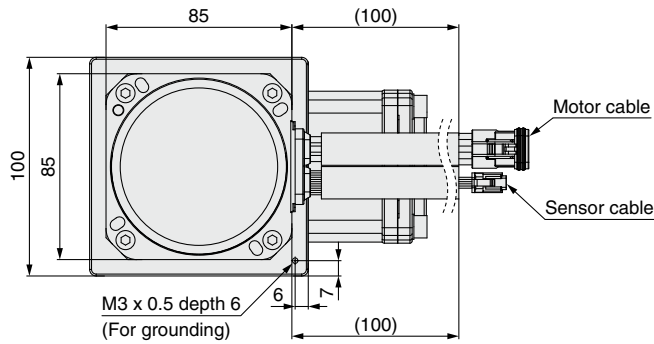

Mounting silencer

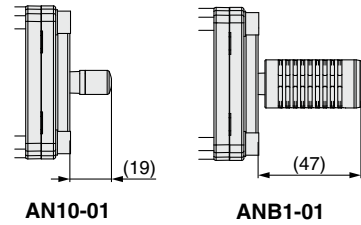

Controller

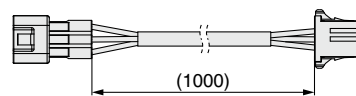
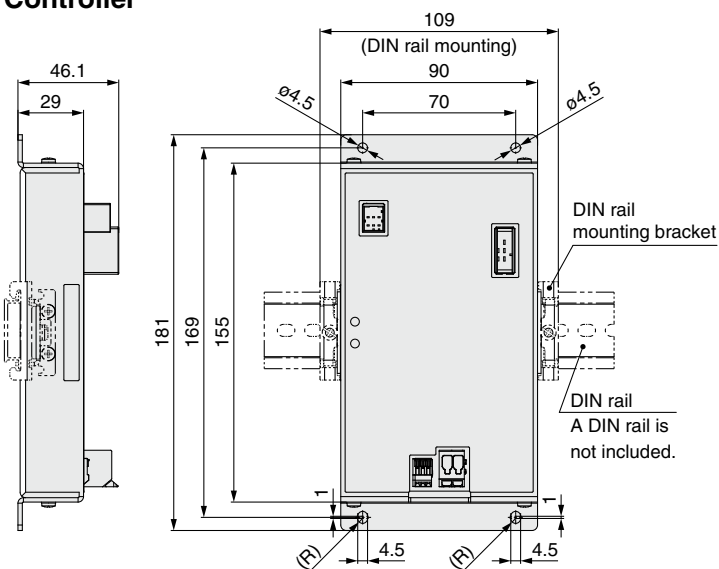

Motor cable

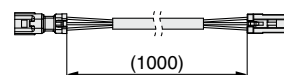

Sensor cable



Dimensions

3-Screen Display High-Precision Digital Pressure Switch ISE20A-Y-□-01-J-X603

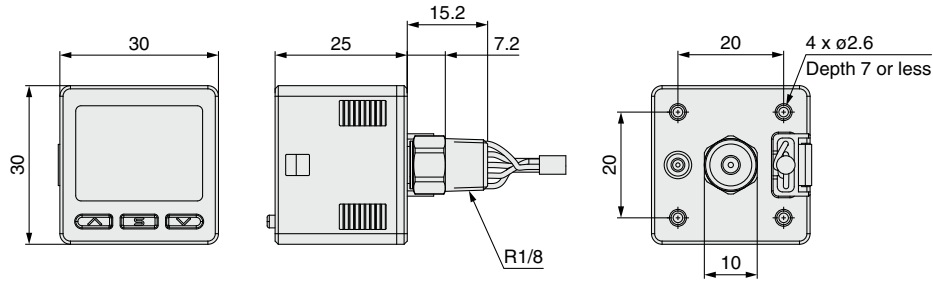

Panel fitting dimensions Individual mounting

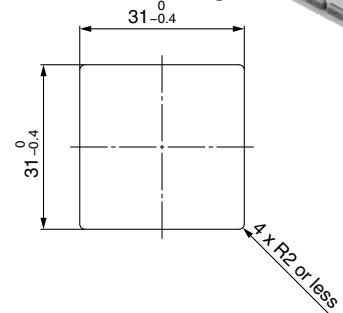

Lead wire with connector For ISE20A (Part no.: ZS-46-5L)

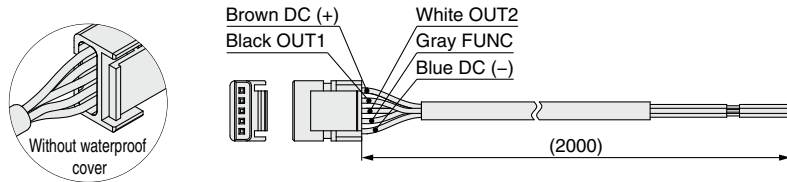

3-Port Solenoid Valve V124-5LU-M5

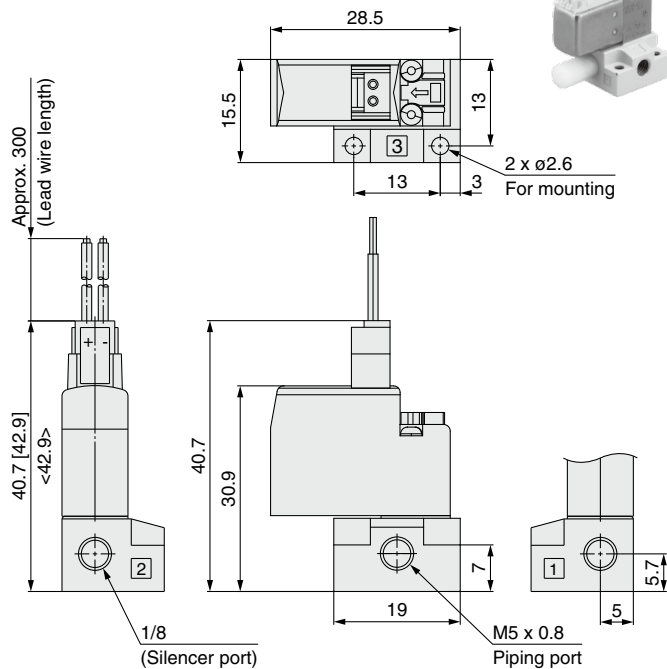

Silencer AN05-M5 Included with the solenoid valve

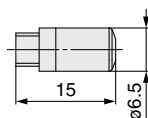

Check Valve with One-touch Fitting AKH06-00

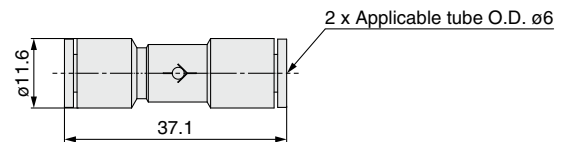

Silencer

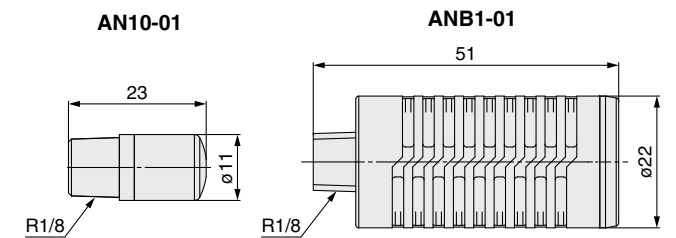

| Symbol | Silencer part no. | Noise (Positive pressure) |
|----------|-------------------|---------------------------|
| A | AN10-01 | 62 dB or less |
| B | ANB1-01 | 55 dB or less |

* A 300 mm connector for the solenoid valve is included in the package.



CRP Series Compact Compressor Specific Product Precautions 1

Be sure to read this before handling the products. Refer to the back cover for safety instructions. For precautions, refer to the “Handling Precautions for SMC Products” and the “Operation Manual” on the SMC website: <https://www.smcworld.com>

Design and Selection

⚠ Danger

- Use this product only for general industrial applications.**
Do not use for any life-supporting applications such as respiratory equipment. Any damage to this product may result in a critical accident.
- Do not intake or discharge fluids other than atmospheric air.**
It could lead to fire, explosion.
- Do not install the product in an environment containing flammable gas, explosive gas, the organic solvents, explosive dust or corrosive gas.**
It could lead to fire, explosion.
- This product (compressor and controller) does not have a waterproof structure.**
Do not use this product in an area where it could get wet, or in environments of high humidity and heavy condensation. This may cause an electric shock, earth leakage, or fire.
- Do not disassemble the product or make any modifications.**
It may cause human injury and/or an accident.
- The product becomes hot during operation. Touching it may cause burn injuries. In addition, residual heat after turning off the power may cause burn injuries. Avoid touching the product until it has cooled down sufficiently.**
- The product contains a fan and parts that rotate at high speeds during operation. There is a risk of fingers or hand being cut or getting caught by rotating objects. Avoid touching the product during operation.**

⚠ Warning

- When using this product in critical applications, make sure to provide a spare device or auxiliary equipment.**
This prevents damage when the operation is stopped due to failure or activation of the safety system.
- Install an emergency stop circuit.**
Install an emergency stop circuit in accordance with EN 60204-1 using an appropriate electrical disconnection device (complying with the required standards) to remove the electrical power and an appropriate device to vent the pneumatic pressure safely. Pay particular attention to the current rating of the disconnection device, the maximum trip current of the recommended 6A B-type circuit breaker is 30A. The pneumatic venting device should meet the required vent capacity appropriate to the system volume and required discharge time and be silenced to the required level.
- Consider emergency stops.**
Design so that human injury and/or damage to machinery and equipment will not be caused when machinery is stopped by a safety device under abnormal conditions, such as a power outage or a manual emergency stop.
- Consider the whole system.**
Design the system so that human injury or equipment damage will not occur upon the restart of operation of the whole system.

Design and Selection

⚠ Caution

- Depending on the operating conditions, the surface temperature of the product may reach up to approx. 90 to 100°C and the discharged air temperature may be up to approx. 70°C. Confirm that the generated heat does not affect the surrounding.
- Provide measures to treat the drain according to the use of compressed air.**
This product does not use any lubricating oil during the compression process. However, the compressed air generated contains a drain made of impurities such as moisture, oil content, dust, and wear particles from the atmosphere.
Make sure to consider methods of treating this drain as it may cause malfunction if it flows into pneumatic equipment such as cylinders.

Mounting

⚠ Warning

- If the vibration transferred to the embedded structure deemed large, provide appropriate vibration-proof treatment when fastening the product.**
Vibration may transfer to the structure and increase the noise level.

⚠ Caution

- This product exhausts heat using an axial flow fan. Make sure the suction and exhaust grill are unobstructed when installing the product.**
The temperature protection system will activate if the motor overheats and stop the operation.

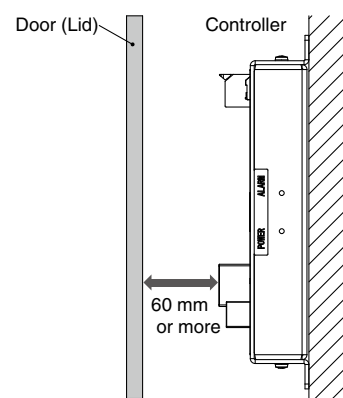
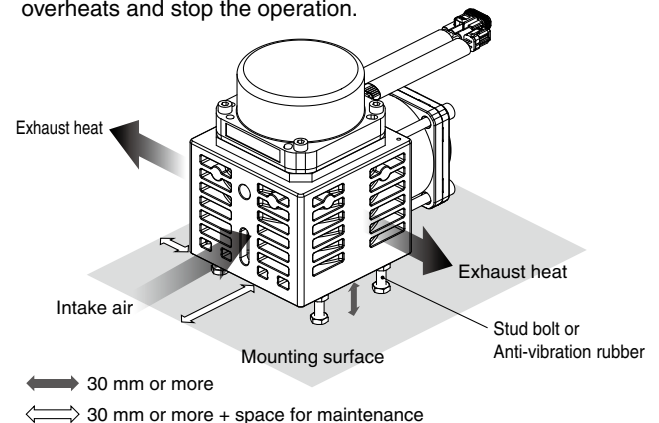



CRP Series Compact Compressor Specific Product Precautions 2

Be sure to read this before handling the products. Refer to the back cover for safety instructions. For precautions, refer to the “Handling Precautions for SMC Products” and the “Operation Manual” on the SMC website: <https://www.smcworld.com>

Wiring

⚠ Caution

1. Be sure to carry out grounding in order to ensure the noise tolerance.

The ground points should be near the compressor or the controller to make the wire length shorter.

Piping

⚠ Caution

1. Start-up of this product may be unstable or disabled while it is still pressurized.

Release the pressure inside before restarting the product.

Pneumatic circuit diagram

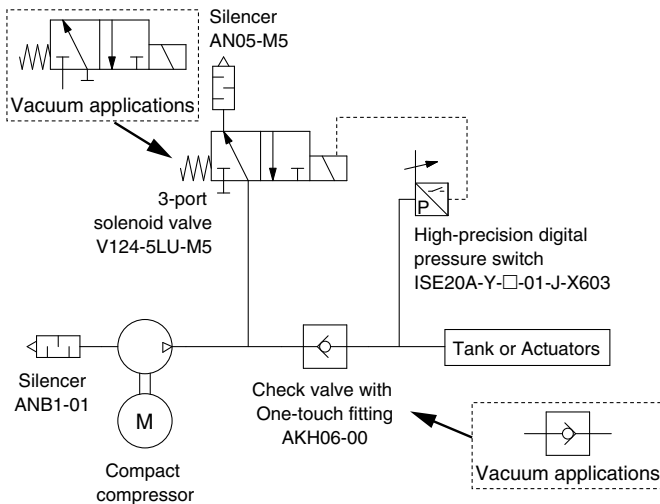

2. Make sure to mount a silencer on the inlet port for positive pressure and on the discharge port for vacuum.

This will reduce the noise and prevent intrusion of any foreign matter.

Handling

⚠ Caution

1. Do not switch the suction and exhaust ports to change from a positive pressure (compressor) application to a vacuum (vacuum pump) application.

The performance will be significantly reduced. This warning also applies in the opposite situation.

2. When this product is operated under certain conditions, the operating life is 3000 hours (reference value).

Refer to the operation manual for detailed conditions.

Compliance

1. EMC Directive/Regulations

This product conforms to the applicable CE/UKCA, EMC Directive/Regulations as stated on the Declaration of Conformity when used on its own in accordance with the instructions.

When installed in the finished machine, the conformity with the applicable CE/UKCA, EMC Directive/Regulations shall be confirmed before putting into service.

2. Machinery Directive/Regulations

This product is partly completed machinery under the CE/UKCA, Machinery Directive/Regulations and has been supplied with a Declaration of Incorporation.

When installed in the finished machine, the conformity with the applicable essential health and safety requirements of the CE/UKCA, Machinery Directive/Regulations shall be confirmed.

Safety Instructions

These safety instructions are intended to prevent hazardous situations and/or equipment damage. These instructions indicate the level of potential hazard with the labels of “**Caution**,” “**Warning**” or “**Danger**.” They are all important notes for safety and must be followed in addition to International Standards (ISO/IEC)*1), and other safety regulations.

 **Danger :** **Danger** indicates a hazard with a high level of risk which, if not avoided, will result in death or serious injury.

 **Warning:** **Warning** indicates a hazard with a medium level of risk which, if not avoided, could result in death or serious injury.

 **Caution:** **Caution** indicates a hazard with a low level of risk which, if not avoided, could result in minor or moderate injury.

*1) ISO 4414: Pneumatic fluid power - General rules and safety requirements for systems and their components
ISO 4413: Hydraulic fluid power - General rules and safety requirements for systems and their components
IEC 60204-1: Safety of machinery - Electrical equipment of machines - Part 1: General requirements
ISO 10218-1: Robots and robotic devices - Safety requirements for industrial robots - Part 1: Robots etc.

Warning

1. The compatibility of the product is the responsibility of the person who designs the equipment or decides its specifications.

Since the product specified here is used under various operating conditions, its compatibility with specific equipment must be decided by the person who designs the equipment or decides its specifications based on necessary analysis and test results. The expected performance and safety assurance of the equipment will be the responsibility of the person who has determined its compatibility with the product. This person should also continuously review all specifications of the product referring to its latest catalog information, with a view to giving due consideration to any possibility of equipment failure when configuring the equipment.

2. Only personnel with appropriate training should operate machinery and equipment.

The product specified here may become unsafe if handled incorrectly. The assembly, operation and maintenance of machines or equipment including our products must be performed by an operator who is appropriately trained and experienced.

3. Do not service or attempt to remove product and machinery/equipment until safety is confirmed.

1. The inspection and maintenance of machinery/equipment should only be performed after measures to prevent falling or runaway of the driven objects have been confirmed.
2. When the product is to be removed, confirm that the safety measures as mentioned above are implemented and the power from any appropriate source is cut, and read and understand the specific product precautions of all relevant products carefully.
3. Before machinery/equipment is restarted, take measures to prevent unexpected operation and malfunction.

4. Our products cannot be used beyond their specifications. Our products are not developed, designed, and manufactured to be used under the following conditions or environments. Use under such conditions or environments is not covered.

1. Conditions and environments outside of the given specifications, or use outdoors or in a place exposed to direct sunlight.
2. Use for nuclear power, railways, aviation, space equipment, ships, vehicles, military application, equipment affecting human life, body, and property, fuel equipment, entertainment equipment, emergency shut-off circuits, press clutches, brake circuits, safety equipment, etc., and use for applications that do not conform to standard specifications such as catalogs and operation manuals.
3. Use for interlock circuits, except for use with double interlock such as installing a mechanical protection function in case of failure. Please periodically inspect the product to confirm that the product is operating properly.

Caution

We develop, design, and manufacture our products to be used for automatic control equipment, and provide them for peaceful use in manufacturing industries.

Use in non-manufacturing industries is not covered.

Products we manufacture and sell cannot be used for the purpose of transactions or certification specified in the Measurement Act.

The new Measurement Act prohibits use of any unit other than SI units in Japan.

Limited warranty and Disclaimer/ Compliance Requirements

The product used is subject to the following “Limited warranty and Disclaimer” and “Compliance Requirements”.

Read and accept them before using the product.

Limited warranty and Disclaimer

1. The warranty period of the product is 1 year in service or 1.5 years after the product is delivered, whichever is first.*2)
Also, the product may have specified durability, running distance or replacement parts. Please consult your nearest sales branch.
2. For any failure or damage reported within the warranty period which is clearly our responsibility, a replacement product or necessary parts will be provided.
This limited warranty applies only to our product independently, and not to any other damage incurred due to the failure of the product.
3. Prior to using SMC products, please read and understand the warranty terms and disclaimers noted in the specified catalog for the particular products.

*2) **Vacuum pads are excluded from this 1 year warranty.**

A vacuum pad is a consumable part, so it is warranted for a year after it is delivered.

Also, even within the warranty period, the wear of a product due to the use of the vacuum pad or failure due to the deterioration of rubber material are not covered by the limited warranty.

Compliance Requirements

1. The use of SMC products with production equipment for the manufacture of weapons of mass destruction (WMD) or any other weapon is strictly prohibited.
2. The exports of SMC products or technology from one country to another are governed by the relevant security laws and regulations of the countries involved in the transaction. Prior to the shipment of a SMC product to another country, assure that all local rules governing that export are known and followed.

Safety Instructions

Be sure to read the “Handling Precautions for SMC Products” (M-E03-3) and “Operation Manual” before use.

SMC Corporation

Akihabara UDX 15F,
4-14-1, Sotokanda, Chiyoda-ku, Tokyo 101-0021, JAPAN
Phone: 03-5207-8249 Fax: 03-5298-5362
<https://www.smcworld.com>
© 2023 SMC Corporation All Rights Reserved

Specifications are subject to change without prior notice and any obligation on the part of the manufacturer.

D-G