

Directional Control Driver for Electric Cylinder

LC3F2 Series



LC3F212-5A3□

LC3F212-5A5□



LEF
LEJ
LEL
LEM
LEY
LES
LEPY
LEPS
LER
LEH
LEY-X5
11-LEFS
11-LEJS
25A-
LEC□
LEC
S□
LEC
SS-T
LEC
Y□
Motorless
LAT
LZ□

Able to control the stroke with only ON/OFF signals.

Directional control driver like a solenoid valve

Able to set thrust arbitrarily.

Thrust can be adjusted by adjustment trimmer.

Able to control with only 3 different types of input signals.

- ① Directional instruction
- ② Thrust selection
- ③ Output ON/OFF

Can be operated manually.

Maintenance performance for wiring check has been improved.

Product Specifications

Model	LC3F212-5A3□	LC3F212-5A5□
Power supply	24 VDC ± 10%	
Front side label color	Max. 1.3 A	Max. 2.3 A
Input signal	Gray	
Selection of thrust	Blue	
Ambient temperature	Photocoupler input 24 VDC ±10% Max. 8 mA/point	
Ambient humidity	100% or set value (Setting range 10 to 70% F.S.)	
Environment	+5 to 40°C	
Display LED	35 to 85% Rh (No condensation)	
Weight	Indoor (Direct sunlight should be avoided.) No corrosive gas, inflammable gas, oil mist or dust particle	
	POWER, A-PHASE, OFF, SET	
	145 g	

Directional Control Driver for Electric Cylinder

LC3F2 Series

How to Order

LC3F212 - 5 **A3** **B**

Power supply

5 24 VDC

Applicable motor

A3	DC motor (Cylinder size 3)
A5	DC motor (Cylinder size 5)

Housing set (Connector set)

A	Housing for CN1, 2, 3 (connector) & contact (connector pin) are included as an accessory.
B	Nothing included.

Option

● Cable for power supply terminal

LC3F2 - 1 - C1 - 02 - 1

Cable type

C1	Cable for CN1 power supply terminal
----	-------------------------------------

Cable length

01	1 m
02	2 m

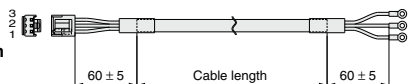

CN1 Power Supply Terminal Table

Terminal	Function	Pin number	Optional cable color
FG	Frame ground	1	Yellow/Green
DC (+)	Driver power supply (+24 V)	2	Brown
DC (-)	Driver power supply (0 V)	3	Blue

● Cable for control terminal

LC3F2 - 1 - C2 - 02 - 1

Cable type

C2	Cable for CN2 control terminal
----	--------------------------------

Cable length

01	1 m
02	2 m

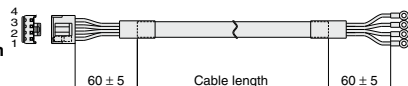

CN2 Control Terminal Table

Terminal	Function	Pin number	Optional cable color
COM	Common terminal	1	White
ON	Output ON command input	2	Red
SET	Adjusted thrust command input	ON: Motor output OFF: No motor output	Yellow
		ON: Adjusted thrust OFF: 100% thrust (Max. thrust)	
A-PHASE	Traveling direction command input	ON: A-PHASE (Retracted side) OFF: B-PHASE (Extended side)	Orange

● Cable for motor output terminal

LC3F2 - 1 - C3 - 02 - 1

Cable type

C3	Cable for CN3 motor output terminal
----	-------------------------------------

Cable length

02	2 m
05	5 m

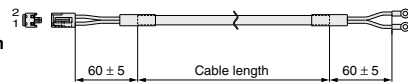

CN3 Motor Output Terminal Table

Terminal	Function	Pin number	Optional cable color
OUTA	Motor output A (Blue)	1	Blue
OUTB	Motor output B (Red)	2	Red

● Housing set (Connector set)

LC3F2 - 1 - C0

Housing for power supply terminal (Connector)	1 pc.	VHR-3N: J.S.T. Mfg Co., Ltd.
Housing for control terminal (Connector)	1 pc.	VHR-4N: J.S.T. Mfg Co., Ltd.
Housing for motor output terminal (Connector)	1 pc.	VHR-2N: J.S.T. Mfg Co., Ltd.
Contact (Connector pin)	12 pcs.	BVH-21T-P1.1: J.S.T. Mfg Co., Ltd.

⚠ Caution

- **Do not apply repetitive bending or pulling stress to the cable.**
Wiring with repetitive bending or pulling stress to the cable will likely cause the cable to break.
- **In the event of crimping the contact (connector pin) and wire, use the specified tools as well as the recommended cable.**
Crimping tool: YC-160R (J.S.T. Mfg Co., Ltd.)
Pulling tool: EJ-NV (J.S.T. Mfg Co., Ltd.)
Recommended cable connection (common for individual cable) AWG21 (0.5 mm²), Insulated wire O.D. 1.7 to 3.0 mm with shield, Heat resistance is more than 80°C.
Maximum cable length $\left(\begin{array}{l} \text{CN1 cable for power supply terminal} \quad 2 \text{ m} \\ \text{CN2 cable for control terminal} \quad 2 \text{ m} \\ \text{CN3 cable for motor output terminal} \quad 5 \text{ m} \end{array} \right.$
- **Shield is attached with an optional cable for the LC3F2 series.**
When grounding a shield, remove the sheath and use a metal U-crip or P-crip.

Applicable Cylinder Table

Cylinder part no.	Applicable directional control driver
L□Z□□3□-□□□A3□-□□□□	LC3F212-5A3□
L□Z□□5□-□□□A5□-□□□□	LC3F212-5A5□

Dimensions

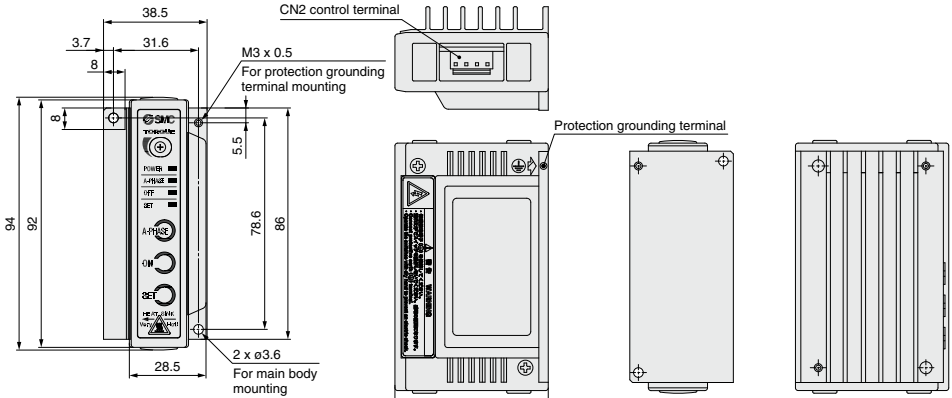

Mounting

⚠ Caution

Consider the cooling period, so that the operating temperature of main body should be within the range of specifications. Also, allow enough distance from each side of the main body, construction and the parts.

Cooling should be considered, so the surface temperature of a heat sink should not be more than 50°C even though the temperature is within the operating range.

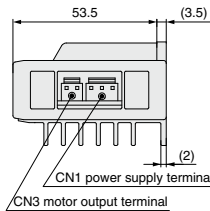
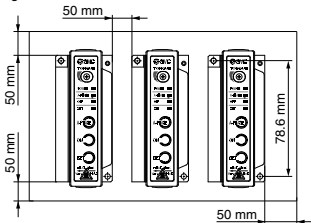

Protection grounding terminal related components	Cross recessed bind screw M3 x 4	1 pc.
	Spring washer Nominal 3	1 pc.
	Tooth lock washer (A) Nominal 3	1 pc.

Related components for mounting the protection grounding terminal are provided together with the product.

How to Mount

Mount the directional control driver vertically against the wall, using two mounting screw holes, so the front side (on which its adjustment trimmer and manual switch are located) is facing to an operator.

Applicable mounting screw: M3 (2 pcs.) [to be supplied by customer]

* How to mount a protection grounding terminal

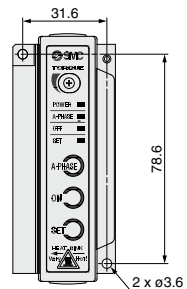
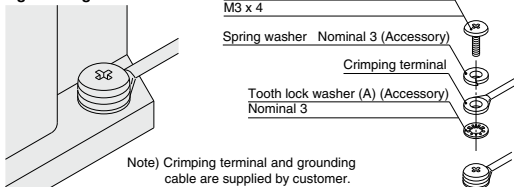

- LEF
- LEJ
- LEL
- LEM
- LEY
- LES
- LEPY
- LEPS
- LER
- LEH
- LEY-X5
- 11-LEFS
- 11-LEJS
- 25A-
- LEC□
- LEC
- SS
- LEC
- SS-T
- LEC
- Y□
- Motor-less
- LAT
- LZ□
- LC3F2

LC3F2 Series

Wiring Example

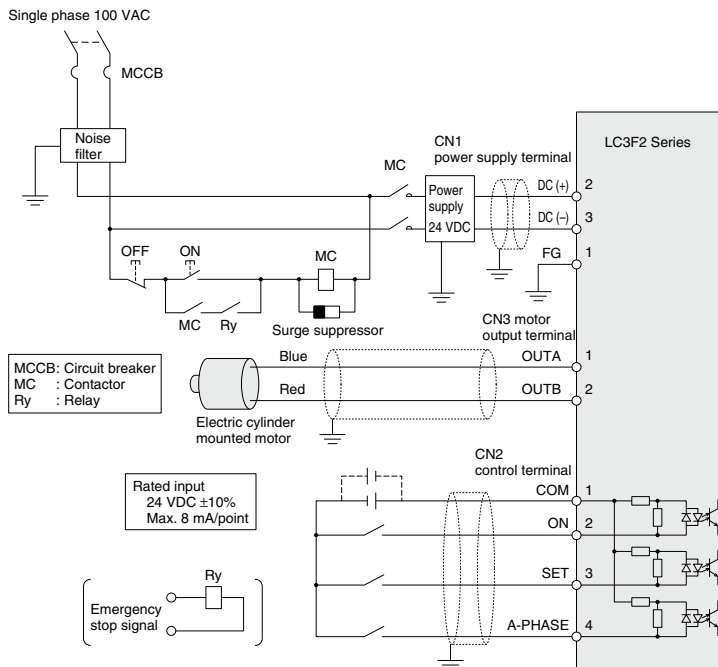

For System Chart, refer to page 926.

Warning

Do not short circuit the motor output terminal (CN3). Excessive current will flow, and the directional control driver may become damaged.

How to wire

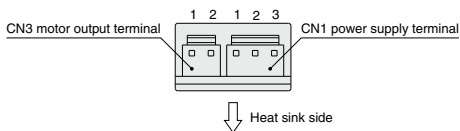

CN1 Power Supply Terminal

Pin no.	Terminal	Function
1	FG	Frame ground
2	DC (+)	Driver power supply (+24 V)
3	DC (-)	Driver power supply (0 V)

Housing: VHR-3N (J.S.T. Mfg Co., Ltd.)
Contact: BVH-21T-P1.1 (J.S.T. Mfg Co., Ltd.)

CN3 Motor Output Terminal

Pin no.	Terminal	Function
1	OUTA	Motor output A (Blue wire)
2	OUTB	Motor output B (Red wire)

Housing: VHR-2N (J.S.T. Mfg Co., Ltd.)
Contact: BVH-21T-P1.1 (J.S.T. Mfg Co., Ltd.)

Caution

There is no emergency stop function or power supply switch in the directional control driver. Please be sure to provide an emergency stop and power supply insulation (insulator) device as a total machine equipment, referencing the above wiring examples. Also, please be sure to turn off the power supply for the whole equipment prior to wiring the directional control driver.

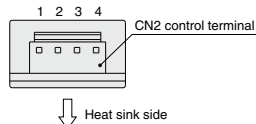

CN2 Control Terminal

Pin no.	Terminal	Function
1	COM	Common terminal
2	ON	Output ON command input ON: Motor output OFF: No motor output
3	SET	Adjusted thrust command input ON: Adjusted thrust OFF: 100% thrust (Max. thrust)
4	A-PHASE	Traveling direction command input ON: A-PHASE (Retracted side) ^{Note} OFF: B-PHASE (Extended side) ^{Note}

Housing: VHR-4N (J.S.T. Mfg Co., Ltd.)
Contact: BVH-21T-P1.1 (J.S.T. Mfg Co., Ltd.)

Note) For the travelling direction (retracted, extended side), refer to the dimensions in pages 930, 932, 936 and 937.

Description of Each Part and its Function

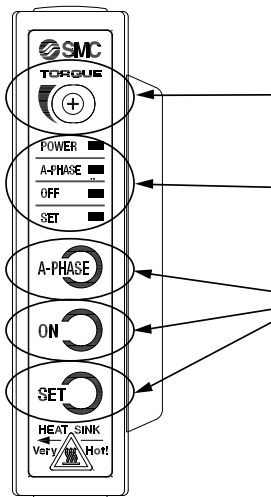

Category	Description	Details
Trimmer	Thrust adjustment trimmer	Thrust changes through adjustment.
Indicator light	POWER	Light illuminates when power is supplied.
	A-PHASE	Light illuminates by A-PHASE command. (Travelling to the retracted side when illuminated)
	OFF	Light illuminates when turning OFF. (No motor output is generated when illuminated.)
	SET	Light illuminates by SET command. (Thrust set by the thrust adjustment trimmer, when illuminated, will be outputted.)
Manual switch	A-PHASE	A-PHASE command while pressing (Travelling to the retracted side)
	ON	ON command while pressing (Motor output will be generated.)
	SET	SET command while pressing (Thrust set by the thrust adjustment trimmer will be outputted.)

⚠ Warning

- Do not operate or adjust settings with wet hands.**
You may experience an electric shock.
- When operating the manual switch, make sure that your hands do not come in contact, or is caught between the workpiece.**
Otherwise you may become injured.

⚠ Caution

- Do not press the manual switch with sharp objects, as the manual switch may be damaged.**
- Do not touch the directional control driver's heat sink.**
It will be very hot while turned on, so operate after you have checked that it has become cold.
- Adjust the thrust adjustment trimmer under the conditions below.**
 - Adjust so that the pressure applied to the thrust adjustment trimmer remain below 4.9 N.
 - The adjustment section of the thrust adjustment trimmer should be below 68.6 mN·m.

Timing Chart

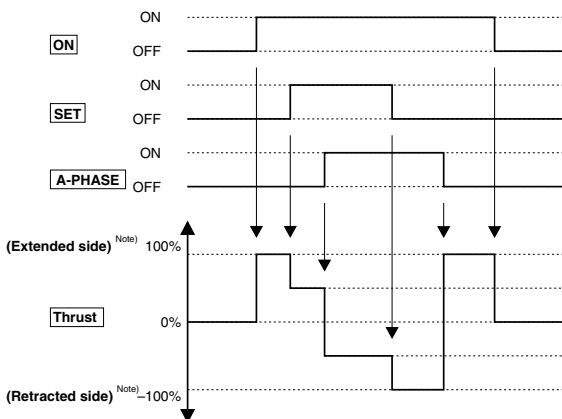

CN2 Control Terminal

Pin no.	Terminal	Function	
1	COM	Common terminal	
2	ON	Output ON command input	ON: Motor output OFF: No motor output
3	SET	Adjusted thrust command input	ON: Adjusted thrust OFF: 100% thrust (Max. thrust)
4	A-PHASE	Traveling direction command input	ON: A-PHASE (Retracted side) OFF: B-PHASE (Extended side)

Housing: VHR-4N (J.S.T. Mfg Co., Ltd.)
 Contact: BVH-21T-P1.1 (J.S.T. Mfg Co., Ltd.)
 (Note) For the travelling direction (retracted, extended side), refer to the dimensions in pages 930, 932, 936 and 937.

(Note) For the travelling direction (retracted, extended side), refer to the dimensions in pages 930, 932, 936 and 937.

LEF
LEJ
LEL
LEM
LEY
LES
LEPY
LEPS
LER
LEH
LEY-X5
11-LEFS
11-LEJS
25A-
LEC
LEC
LEC SS-T
LEC Y
Motor-less
LAT
LZ
LC3F2



Directional Control Driver Specific Product Precautions

Be sure to read this before handling the products.

Caution on Design and Operation

1. If an electric cylinder with DC motor should be rotated by the larger external force than the generated thrust, the reverse inrush voltage generated may cause adverse effects on the electric cylinders directional control driver and result in malfunction or damage to the product.

Example)

- Do not push or pull a cylinder rod, applying a larger load or external force than the generated thrust. (Please use caution if the generated thrust should be switched over between a high thrust and a low thrust.)

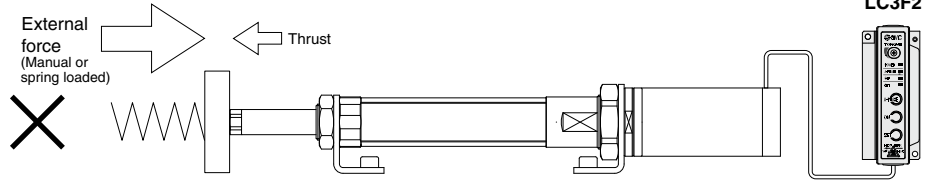

- Do not use this product by stopping it with a load or external force. (control operation)

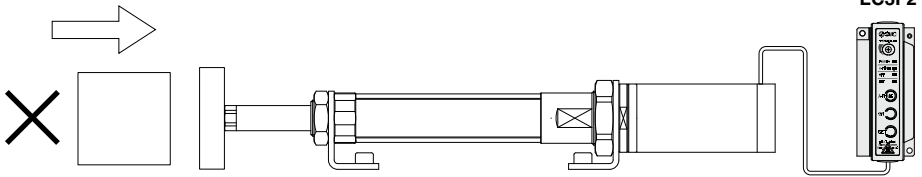

- Command an operation in the reverse direction only after a cylinder rod stopped completely.

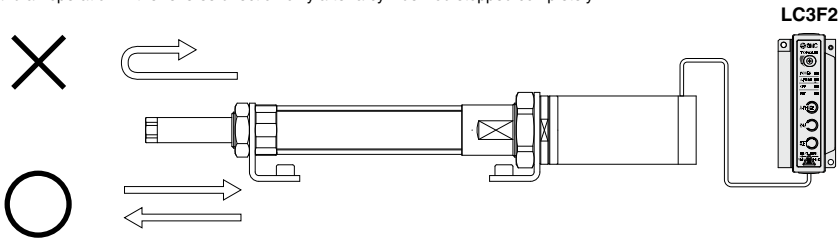

- Do not operate a cylinder rod with an external force when the electric cylinder directional control driver is turned off or output is in the off state. (If a cylinder rod needs to be moved manually for the purpose of adjustment, etc., be sure to remove the CN3 motor output terminal beforehand.)

