

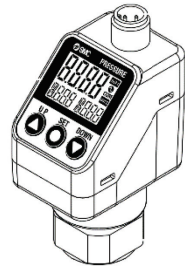

ORIGINAL INSTRUCTIONS

Instruction Manual High Precision Digital Pressure Switch ISE70/71



IO-Link

The intended use of the pressure switch is to measure and display the pressure of fluid and to provide an output signal.

1 Safety Instructions

These safety instructions are intended to prevent hazardous situations and/or equipment damage. These instructions indicate the level of potential hazard with the labels of "Caution," "Warning" or "Danger." They are all important notes for safety and must be followed in addition to International Standards (ISO/IEC^{*)}, and other safety regulations.

- ^{*)} ISO 4414: Pneumatic fluid power - General rules relating to systems.
- ISO 4413: Hydraulic fluid power - General rules relating to systems.
- IEC 60204-1: Safety of machinery - Electrical equipment of machines. (Part 1: General requirements)
- ISO 10218-1: Manipulating industrial robots - Safety, etc.
- Refer to product catalogue, Operation Manual and Handling Precautions for SMC Products for additional information.
- Keep this manual in a safe place for future reference.

Caution	Caution indicates a hazard with a low level of risk which, if not avoided, could result in minor or moderate injury.
Warning	Warning indicates a hazard with a medium level of risk which, if not avoided, could result in death or serious injury.
Danger	Danger indicates a hazard with a high level of risk which, if not avoided, will result in death or serious injury.

Warning

- Always ensure compliance with relevant safety laws and standards.
- All work must be carried out in a safe manner by a qualified person in compliance with applicable national regulations.
- This product is class A equipment intended for use in an industrial environment. There may be potential difficulties in ensuring electromagnetic compatibility in other environments due to conducted or radiated disturbances. Otherwise electric shock, malfunction or product damage can result.
- Refer to the operation manual on the SMC website (URL: <https://www.smcworld.com>) for more safety instructions.

2 Specifications

2.1 General specifications

Product No.	ISE70	ISE71	
Applicable fluid	Air, non-corrosive and non-flammable gas		
Pressure	Rated pressure range	0 to 1.000 MPa	0 to 1.600 MPa
	Display / set pressure range	-0.105 to 1.050 MPa	-0.105 to 1.680 MPa
	Minimum setting unit	0.001 MPa	
	Proof pressure	1.5 MPa	2.4 MPa
Electrical	Power supply as switch output device	12 to 24 VDC ±10% with 10% Voltage ripple or less (p-p)	
	Power supply as IO-Link device	18 to 30 VDC, including 10% voltage ripple (p-p)	
	Current consumption	35 mA or less	
	Protection	Polarity protection	
Accuracy	Display accuracy	±2% F.S. ±1 digit (at ambient 25±3 °C)	
	Repeatability	±0.5% F.S.	
	Temp. characteristics	±2% F.S. (25 °C standard)	
Switch output	Output type	NPN or PNP open collector output	
	Output mode	Hysteresis mode, window comparator mode, error or switch output OFF	
	Switch operation	Normal or reversed output	
	Max. Load current	80 mA	
	Max. Applied voltage	30 V (during NPN output)	
	Internal voltage drop (Residual voltage)	1.5 V or less (Load current 80 mA)	
	Delay time	1.5 ms or less (for anti-chatter function: variable at 0 to 60 s / 0.01 step)	
	Hysteresis or Window comparator mode	Variable from 0	
	Short circuit protection	Provided	
	Display	Units	MPa, kPa, kgf/cm ² , bar, psi
Display type		LCD	
Number of displays		3-screen display (Main display, sub display x 2)	
Display colour		Main display: Red/Green, Sub display: Orange	
Number of display digits		Main display: 4 digits (7-segments) Sub display: 4 digits (Upper 1 digit 11-segments, 7-segments for other)	
	Operation light	LED is ON when switch output is ON (OUT1, OUT2: Orange)	
Digital filter	Variable from 0 to 30 s / 0.01 step		

2.2 IO-Link specifications

IO-Link type	Device
IO-Link version	V1.1
Communication speed	COM2 (38.4 kbps)
Min. cycle time	2.3 ms
Process data length	Input Data: 2 byte, Output Data: 0 byte
On request data comms.	Available
Data storage function	Available
Event function	Available
Vendor ID	131 (0x0083)
Device ID	ISE70*-L2*: 307 (0x0133) ISE71*-L2*: 308 (0x0134)

Warning

Special products (-X) might have specifications different from those shown in this section. Contact SMC for specific drawings.

3 Names of Individual parts

3.1 Product

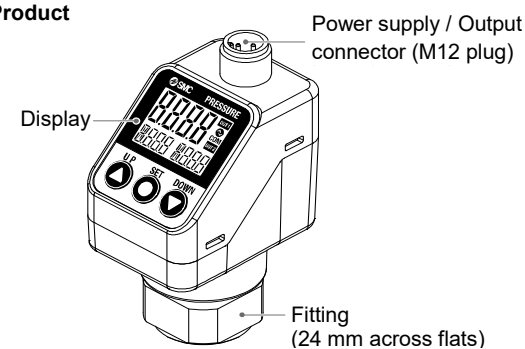

3.2 Display

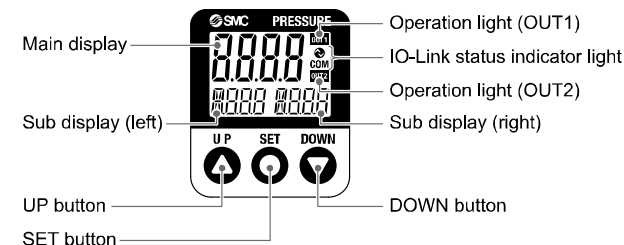

Part	Description
Operation Light	Displays the switch operating condition
Main display	Displays pressure measurement values and error codes (2 colour display).
Sub display (left)	Displays items (Orange)
Sub display (right)	Displays set values, peak and bottom values. (Orange)
UP button	Increases mode and ON/OFF set values.
DOWN button	Decreases mode and ON/OFF set values.
SET button	Changes the mode and confirms the settings.
IO-Link status indicator light	Displays OUT1 output communication status (SIO mode, start-up mode, operation mode) and the presence of communication data.

4 Installation

4.1 Installation

Warning

- Do not install the product unless the safety instructions have been read and understood.

4.2 Environment

Warning

- Do not install in a location subject to vibration or impact in excess of the product's specifications.
- Do not mount in a location exposed to radiant heat that would result in temperatures in excess of the product specification.

4.3 Mounting with Bracket

Mount the bracket to the product using mounting screws supplied (M4x6 L (2 pcs)) then set the product in the required position. Tighten the bracket mounting screws to a torque of 0.76 ±0.1 N•m.

Bracket A (Part No. ZS-50-A)

Bracket B (Part No. ZS-50-B)

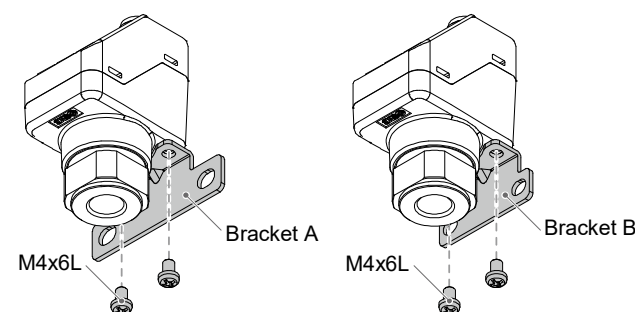

4 Installation (continued)

4.4 Piping

Caution

- Before connecting piping make sure to clean up chips, cutting oil, dust.
- After hand tightening, tighten the fitting using a spanner on the flat surfaces of the fitting (24 mm A/F).
- When tightening, do not hold the upper part of the product (display) with the spanner.
- For Rc1/4 and NPT1/4 threads the tightening torque must be 8 to 12 N•m. For G1/4 thread the tightening torque must be 4 to 5 N•m.

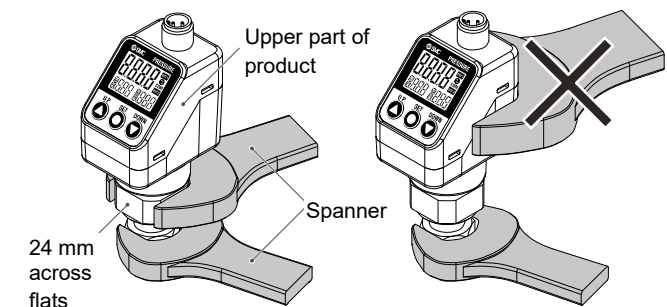

4.5 Display Rotation

- During installation, the upper part (display) of the product can be rotated by 336°. Take care as rotating the display with excessive force will damage the end stopper.

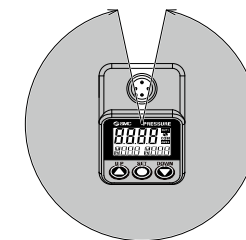

4.6 Wiring

- Connections should be made with the power supply turned off.
- Use a separate route for the product wiring and any power or high voltage wiring. Otherwise, malfunction may result due to noise.
- If a commercially available switching power supply is used, be sure to ground the frame ground (FG) terminal. If a switching power supply is connected, noise will be superimposed and will not meet the product specifications. Insert a noise filter such as a line noise filter/ferrite between the switching power supplies or change the switching power supply to the series power supply.

How to use connector

Align the cable connector key groove with the product connector key to insert and rotate the knurled part of the connector. Connect the wires of the lead wire to the M12 connector as shown below.

M12 Connector (Port class A)

1) When used as a switch output device

No.	Name	Colour	Function
1	DC(+)	Brown	12 to 24 VDC
2	OUT2	White	Switch output 2
3	DC(-)	Blue	0 V
4	OUT1	Black	Switch output 1

2) When used as an IO-Link device

No.	Name	Colour	Function
1	L+	Brown	18 to 30 VDC
2	DO	White	Switch output 2
3	L-	Blue	0 V
4	C/Q	Black	Communication data (IO-Link) / Switch output 1 (SIO)

IO-Link

5 Setting (Measurement mode)

Power is supplied

Product code is displayed for 3 seconds

[Measurement mode]
 Detects the pressure and indicates the display and switch operating status. This is the basic mode; other modes should be selected for set-point changes and other function settings.

Measurement Mode display

Sub display
 In measurement mode, the sub display can be temporarily changed by pressing the UP or DOWN buttons.

*: Arbitrary display mode can be added to the sub display by setting the [F10] sub display. If the sub display is changed during arbitrary display setting, the display will return to arbitrary display after 30 s. (The default setting does not include arbitrary display).

Press the SET button once

Press the SET button for 1 to 3 s

Press the SET button for 3 to 5 s

[3 step setting mode]
Set value or hysteresis

[Simple setting mode]
Set value, hysteresis and delay time

[Function selection mode]
Change the function settings

[Other settings]
• Zero clear
• Snap lock
• Key Lock

6 Pressure Setting

Default settings

When the pressure exceeds the set value, the switch will be turned ON. When the pressure falls below the set value by the amount of hysteresis or more, the switch will be turned OFF.

The default setting is to turn ON the pressure switch when the pressure reaches the centre of the atmospheric pressure and upper limit of the rated pressure range. If this condition is acceptable, then keep these settings.

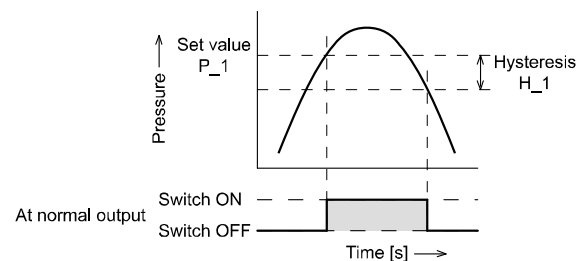

Default setting for Pressure range

Item	ISE70	ISE71
[P_1] Set value of OUT1 [MPa]	0.500	0.800
[H_1] Hysteresis of OUT1 [MPa]	0.050	0.080

7 3 Step Setting mode

• 3 step setting mode (hysteresis mode)

In 3 step setting mode, the set value (P_1 or n_1) and hysteresis (H_1) can be changed. Set the items on the sub display (set value or hysteresis) using the UP and DOWN button. When changing the set value, follow the operation below. The hysteresis setting can be changed in the same way.

- Press the SET button once when the item to be changed is shown on the sub display. The set value on the sub display will start flashing.
- Press the UP or DOWN button to change the set value. When the UP and DOWN buttons are pressed and held simultaneously for 1 second or longer, the set value is displayed as [- - -], and the set value will be the same as the current pressure value automatically (snap shot function). Afterwards, it is possible to adjust the value by pressing the UP or DOWN button.
- Press the SET button to complete the setting.

The Pressure switch turns on within a set pressure range (from P1L to P1H) during window comparator mode. Set P1L, the lower limit of the switch operation, and P1H, the upper limit of the switch operation and WH1 (hysteresis) following the instructions given above.

(When reversed output is selected, the sub display (left) will indicate [n1L] and [n1H].)

- Set OUT2 in the same way.
- Setting of the normal/reverse output switching and hysteresis/window comparator mode switching are performed using the function selection mode [F 1] OUT1 setting and [F 2] OUT2 setting.

8 Simple Setting mode

- Press and hold the SET button between 1 and 3 seconds in measurement mode. [SEt] is displayed on the main display. When the button is released while in the [SEt] display, the current pressure value is displayed on the main display, [P_1] or [n_1] is displayed on the sub display (left), and the set value is displayed on the sub display (right) (Flashing).
- Change the set value using the UP and DOWN button, and press the SET button to set the value. Then, the setting moves to hysteresis setting. (The snap shot function can be used).
- Change the set value with the UP or DOWN button, and press the SET button to set the value. Then, the setting moves to the delay time of the switch output. (The snap shot function can be used).
- The delay time of the switch output can be selected by pressing the UP or DOWN button at the ON and OFF point of the switch output. Delay time setting can prevent the output from chattering. The delay time can be set in the range 0.00 to 60.00 sec. in 0.01 sec. increments.
- Press the SET button for less than 2 seconds to complete the OUT1 setting. [P_2] or [n_2] is displayed on the sub screen (left). Continue with setting OUT2. Press and hold the SET button for 2 seconds or longer to complete the setting. The product will return to measurement mode.

- In window comparator mode, set P1L, the lower limit of the switch operation, and P1H, the upper limit of the switch operation, WH1 (hysteresis) and dth / dtL (delay time) following the instructions given above. (when reversed output is selected, the sub display (left) will indicate [n1L] and [n1H]).
- Set OUT2 in the same way.

9 Function Selection mode

In measurement mode, press the SET button between 3 and 5 seconds to display [F 0]. Select to display the function to be changed [F□□]. Press and hold the SET button for 2 seconds or longer in function selection mode to return to measurement mode.

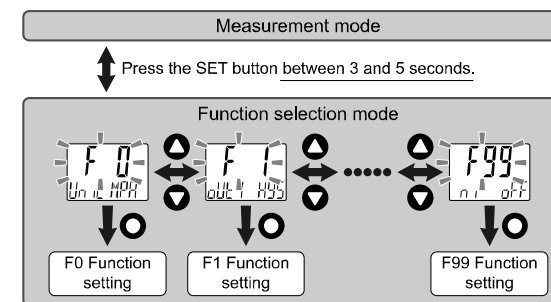

*: Some products do not have all of the functions. If a function is not available or selected due to configuration of other functions, [- - -] is displayed on the sub display.

10 Other Settings

- Peak / Bottom value display
- Snap Shot function
- Zero-clear function
- Key Lock function

Refer to the operation manual on the SMC website (URL: <https://www.smcworld.com>) for further details of how to set these and other functions.

11 Maintenance

11.1 General Maintenance

Caution

- Not following proper maintenance procedures could cause the product to malfunction and lead to equipment damage.
- If handled improperly, compressed air can be dangerous.
- Maintenance of pneumatic systems should be performed only by qualified personnel.
- Before performing maintenance, turn off the power supply and be sure to cut off the supply pressure. Confirm that the air is released to atmosphere.
- After installation and maintenance, apply operating pressure and power to the equipment and perform appropriate functional and leakage tests to make sure the equipment is installed correctly.

How to reset the product after power cut or forcible de-energizing

The setting of the product will be retained as it was before a power cut or de-energizing. The output condition is also basically recovered to that before a power cut or de-energizing, but may change depending on the operating environment.

Therefore, check the safety of the whole installation before operating the product. If the installation is using accurate control, wait until the product has warmed up (approximately 10 to 15 minutes).

12 Troubleshooting

12.1 Error Indication

Error	Error displayed	Description	Measures
Over current error	Er 1 Er 2	The load current applied to the switch output has exceeded the maximum value.	Turn the power off and remove the cause of the over current. Then supply the power again.
Residual pressure error	Er 3	During zero clear operation, pressure greater than $\pm 7\%$ F.S. is present. Note that the mode is returned to measurement mode automatically 1 s later. The zero clear range varies by $\pm 1\%$ F.S. due to variation between individual products.	Release the applied pressure to atmosphere, and retry the zero clear operation.
Pressurize error	HHH	Pressure exceeding the upper limit of the set pressure range is applied.	Reset applied pressure to a level within the set pressure range.
	LLL	Pressure exceeding the lower limit of the set pressure range is applied.	
System error	Er 0 Er 4 Er 6 Er 7 Er 8 Er 9	Displayed if an internal data error has occurred.	Turn the power off and on again. If the failure cannot be solved, contact SMC.
Version does not match	Er 15	Version of master and IO-Link does not match.	Align the master IO-Link version to the device.

If the error cannot be reset after the above measures are taken, or errors other than the above are displayed, please contact SMC.

13 Limitations of Use

13.1 Limited warranty and Disclaimer/Compliance Requirements

Refer to Handling Precautions for SMC Products.

14 Product Disposal

This product shall not be disposed of as municipal waste. Check your local regulations and guidelines to dispose this product correctly, in order to reduce the impact on human health and the environment.

15 Contacts

Refer to www.smcworld.com or www.smc.eu for your local distributor / importer.

SMC Corporation

URL: <https://www.smcworld.com> (Global) <https://www.smc.eu> (Europe)
 SMC Corporation, 4-14-1, Sotokanda, Chiyoda-ku, Tokyo 101-0021, Japan
 Specifications are subject to change without prior notice from the manufacturer.
 © 2021 SMC Corporation All Rights Reserved.
 Template DKP50047-F-085M