

3 Installation - continued

- Installing a silencer to either the exhaust port or the bleed port is recommended for noise reduction and for dust entry prevention.

3.4.2 Vacuum pilot

- When using the VNB□01□V vacuum pilot, maintain the specified pilot pressure by providing a tank with an appropriate capacity or by acquiring the pilot pressure from an area near the vacuum pump.

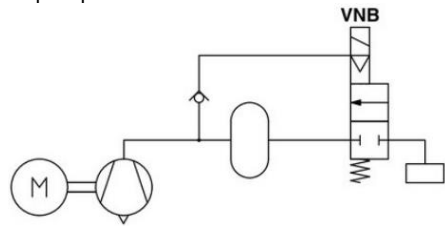

Figure 3

3.5 Air supply

Warning

Use clean air. If the compressed air supply includes chemicals, synthetic materials (including organic solvents), salinity, corrosive gas etc., it can lead to damage or malfunction.

Caution

Install an air filter upstream of the valve. Select an air filter with a filtration size of 5 μm or smaller.

3.6 Electrical circuits

Caution

Surge suppression should be specified by using the appropriate part number. If a valve type without suppression (Type G, E, T, or D) is used, suppression must be provided by the host controller as close as possible to the valve.

3.6.1 VNB1 to 4 (Valve size 1 to 4)

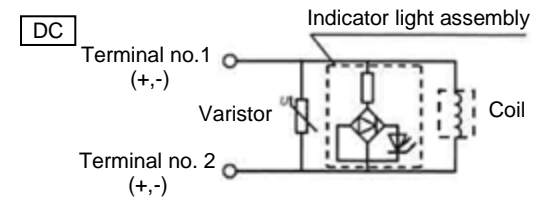
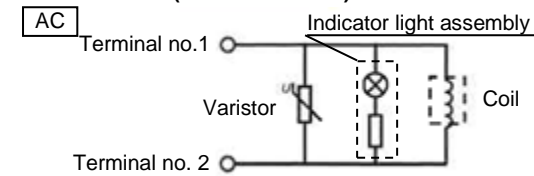

Figure 4

3.6.2 VNB5 to 7 (Valve size 5 to 7), Vacuum pilot type (Valve size 2 to 7)

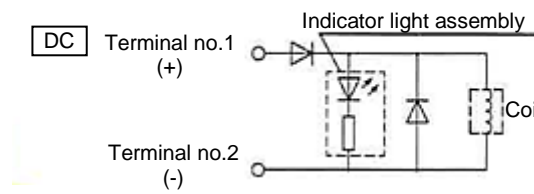
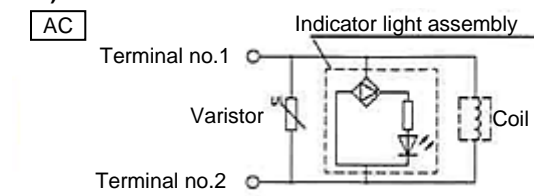

Figure 5

3.7 Electrical connection

- When electrical power is connected to a solenoid valve, be careful to apply the proper voltage. Improper voltage may cause malfunction or coil damage.
- After completing the wiring, confirm that the connections are correct.
- When DC power is connected to a solenoid valve equipped with light and/or surge voltage suppressor, check for polarity indications.

3 Installation - continued

- For polarity indications: Valve sizes 5 to 7 have diodes to protect polarity: If the polarity connection is wrong then the valve will not switch. In addition to this, damage could be caused in the diode in the valve, the switching device at the control equipment or, the power supply.

3.7.1 DIN connector

Refer to catalogue of pilot solenoid valve for additional details.

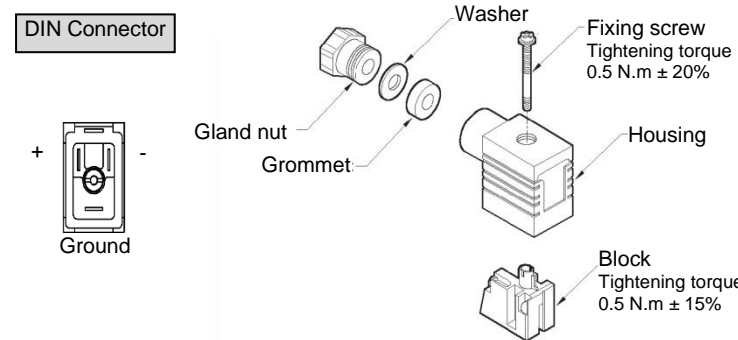

Figure 6

Warning

The ground terminal is connected to the coil assembly only and does not provide a protective earth for the body of the valve.

3.8 Residual voltage

Caution

- If a Zener diode or varistor voltage suppressor is used, the suppressor arrests the back EMF voltage from the coil to a level in proportion to the rated voltage.
- Ensure the transient voltage is within the specification of the host controller.
- Contact SMC for the Zener diode or varistor residual voltage.
- In the case of a diode, the residual voltage is approximately 1 V.
- Valve response time is dependent on surge suppression method

selected.

3.9 Countermeasures for surge voltage

Caution

- At times of sudden interruption of the power supply, the energy stored in a large inductive device may cause non-polar type valves in a de-energised state to switch.
- When installing a breaker circuit to isolate the power, consider a valve with polarity (with polarity protection diode), or install a surge absorption diode across the output of the breaker.

3.10 Mounting

Warning

- Do not apply external force to the coil section.** When tightening is performed, apply a wrench or other tool to the outside of the piping connection parts.
- Mount a valve with its coil position upwards, not downwards.** When mounting a valve with its coil positioned downwards, foreign objects in the fluid will adhere to the iron core leading to malfunction. Especially for strict leakage control, such as with vacuum applications and non-leak specifications, the coil must be positioned upwards.

3.10.1 Bracket (optional)

Valve series 1, 2, 3 and 4 can be mounted using a bracket (optional).

Thread	Appropriate tightening torque [N·m]
M4	1.5
M5	3.0
M6	5.2

Table 10

Refer to catalogue for additional information.

3.11 Manual Override

Warning

- Regardless of an electric signal for the valve, the manual override is used for switching the main valve. Since connected equipment will operate when the manual override is activated, confirm that conditions are safe prior to activation.

3 Installation - continued

- Locked manual overrides might prevent the valve responding to being electrically de-energised or cause unexpected movement in the equipment.

3.11.1 Non-locking push type

- VNB1-4** Push on the manual override button using a small bladed screwdriver until it stops ON. Hold this position for the duration of the check (ON position). Release the button and the override will re-set to OFF position
- VNB5-7** No tool needed.

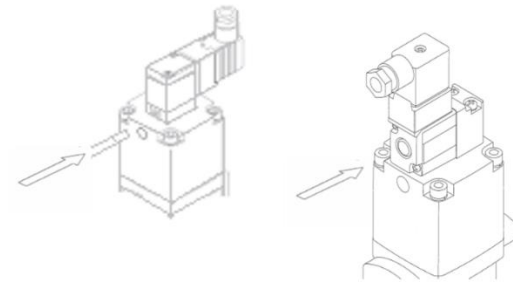

Figure 7. Non-locking push type VNB1-4 (Left) and VNB5-7 (Right)

3.11.2 Push-locking slotted type

- To lock** Using a small-bladed screwdriver in the slot, push the manual override button until it stops. Turn the override button 90° in the direction of the arrow until it stops (ON position). Remove the screwdriver

Warning

In this position the manual override is in the locked 'ON' position.

- To unlock** Place a small-bladed screwdriver in the slot and push the manual override button. Turn the override button 90° in the reverse direction of the arrow. Remove the screwdriver and the manual override will re-set to the OFF position.

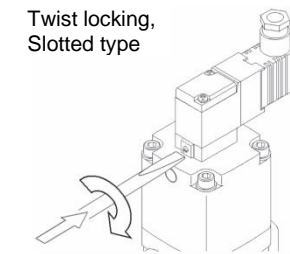

Figure 8. Push locking slotted type

4 How to Order

Refer to catalogue for 'How to Order' or to product drawing for special products.

5 Outline Dimensions

Refer to catalogue for outline dimensions.

6 Maintenance

6.1 General maintenance

Caution

- Not following proper maintenance procedures could cause the product to malfunction and lead to equipment damage.
- If handled improperly, compressed air can be dangerous.
- Maintenance of pneumatic systems should be performed only by qualified personnel.
- Before performing maintenance, turn off the power supply and be sure to cut off the supply pressure. Confirm that the air is released to atmosphere.
- After installation and maintenance, apply operating pressure and power to the equipment and perform appropriate functional and leakage tests to make sure the equipment is installed correctly.
- If any electrical connections are disturbed during maintenance, ensure they are reconnected correctly and safety checks are carried out as required to ensure continued compliance with applicable national regulations.
- Do not make any modification to the product.
- Do not disassemble the product, unless required by installation or maintenance instructions.

6 Maintenance - continued

6.2 Vacuum pilot

When using VNB□□1V N.C. vacuum pilot, maintain the specified pilot pressure by providing a tank with an appropriate capacity or by acquiring the pilot pressure from an area near the vacuum pump.

6.3 Filters and strainers

- Be careful regarding clogging of filters and strainers.
- Replace filter elements after one year of use, or earlier, if the pressure drop reaches 0.1 MPa
- Clean strainers when the pressure drop reaches 0.1 MPa.

6.4 Storage

In case of long term storage after use with heated water, thoroughly remove all moisture to prevent corrosion, and deterioration of rubber materials etc.

6.5 Drain flushing

Remove drainage from air filters regularly. (Refer to the specifications)

6.6 Replacing spare parts

6.6.1 Replacing plate assembly and valve element (see Figure 9)

- Remove body mounting screws.
- Apply sufficient air pressure to pilot port to release plate assembly.
- Place well-fitting slotted screwdriver into slot in piston rod and unscrew seal mounting nut with spanner.
- If spring pin is used, slide pin out and remove valve element.
- Slide off valve element, washers and plate assembly.
- Refitting is reverse of removal (use correct tightening torque).

6.6.2 Replacing Pilot Valve Assembly (see Figure 9)

- Remove pilot valve mounting screws.
- Remove pilot valve (retain DIN plug if necessary).
- Fitting of new pilot valve is reverse of removal assembly (use correct tightening torque).

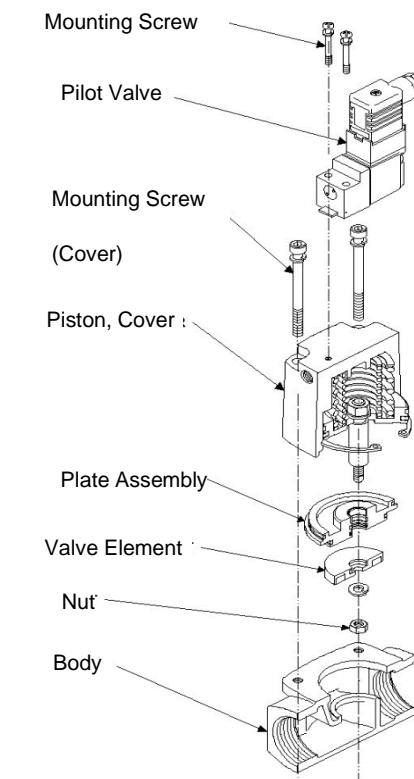

Figure 9

Caution

- Never remove inner circlip from valve.
- When replacing external pilot valve, ensure it is mounted in the correct direction. If mounted in the wrong direction, it may malfunction or leak air.

6 Maintenance - continued

Tightening torque [N·m]

Valve size	VNB1	VNB2	VNB3	VNB4	VNB5	VNB6	VNB7
Seal Mounting Nut	–	1.5	3	3	5.2	12.5	24.5
Piston Cover Mounting screw	1.5	1.5	3	5.2	5.2	12.5	12.5
Pilot Valve Mounting Screw	0.63	0.63	0.63	0.63	1.5	1.5	1.5

Table 11

7 Limitations of Use

Warning

- Do not exceed any of the specifications laid out in section 2 of this document or the specific product catalogue.
- System designer should determine the effect of the possible failure modes of the product on the system.

7.1 Limited warranty and disclaimer/compliance requirements

Refer to Handling Precautions for SMC Products.

Warning

7.2 Effect of energy loss on valve switching

When there is no supply/pilot air, the valve moves to the de-energised position by spring return.

7.3 Extended periods of continuous energization

If a valve is continuously energized for an extended period of time, the temperature of the valve will increase due to the heat generated by the coil. This will likely adversely affect the performance of the solenoid valve and any nearby peripheral equipment. Should a valve be continuously energized for an extended period of time or its daily energized state exceeds its non-energized state, please use an energy saving type valve with DC specification. If an AC type is expected to be energized continuously for long periods of time, select the air-operated valve and use the continuous duty type of the VT307 for a pilot valve.

7.4 Protection against unexpected start-up

Beware of pilot EXH clogging. If the pilot valve leaks and the pilot EXH is blocked, the valve may operate unexpectedly.

7.5 Low temperature operation

- Unless stated otherwise in the special specifications, the valve can be used in ambient temperature as low as -5°C. However, take measures to prevent freezing or solidification of impurities, etc.
- When using valves for water application in cold climates, take

appropriate countermeasures to prevent the water from freezing in tubing after cutting the water supply from the pump, by draining the water, etc. When warming by a heater, etc., be careful not to expose the coil portion to a heater. Installation of a dryer, heat retaining of the body is recommended to prevent freezing condition in which the dew point temperature is high and the ambient temperature is low, and the high flow runs.

7.6 Holding of pressure

Since valves are subject to air leakage, they cannot be used for applications such as holding pressure (including vacuum) in a system.

7.7 Cannot be used as an emergency shut-off valve

This product is not designed for safety applications such as an emergency shut-off valve. If the valves are used in this type of system, other reliable safety assurance measures should be adopted.

7.8 Closed liquid circuit

In a closed circuit, when liquid is static, pressure could rise due to changes in temperature. This pressure rise could cause malfunction and damage to components such as valves. To prevent this, install a relief valve in the system.

7.9 Impact by rapid pressure fluctuation

When an impact caused by the rapid pressure fluctuation, such as water hammer etc., is applied, the solenoid valve may be damaged. Install water hammer relief equipment (accumulator, etc.), or use a SMC water hammer relief valve (e.g. VXR series).

7.10 Safety relays or PLC

If a safe output from a safety relay or PLC is used to operate this valve, ensure that any output test pulse duration is shorter than 1 ms to avoid the valve solenoid responding.

Caution

7.11 Leakage voltage

Ensure that any leakage voltage caused by the leakage current when the switching element is OFF causes $\leq 3\%$ for DC coils, $\leq 20\%$ for AC coils with SF4 pilot valve or $\leq 15\%$ for AC coils with VO307 pilot valve, of the rated voltage across the valve.

8 Product disposal

This product shall not be disposed of as municipal waste. Check your local regulations and guidelines to dispose this product correctly, in order to reduce the impact on human health and the environment.

9 Contacts

Refer to www.smcworld.com or www.smc.eu for your local distributor/importer.

SMC Corporation

URL : <https://www.smcworld.com> (Global) <https://www.smc.eu> (Europe)
 'SMC Corporation, 4-14-1, Sotokanda, Chiyoda-ku, Tokyo 101-0021, Japan
 Specifications are subject to change without prior notice from the manufacturer.
 © 2022 SMC Corporation All Rights Reserved.
 Template DKP50047-F-085I